

F3200 Metal Screen Filter with Hydraulic Operation (Automatic)

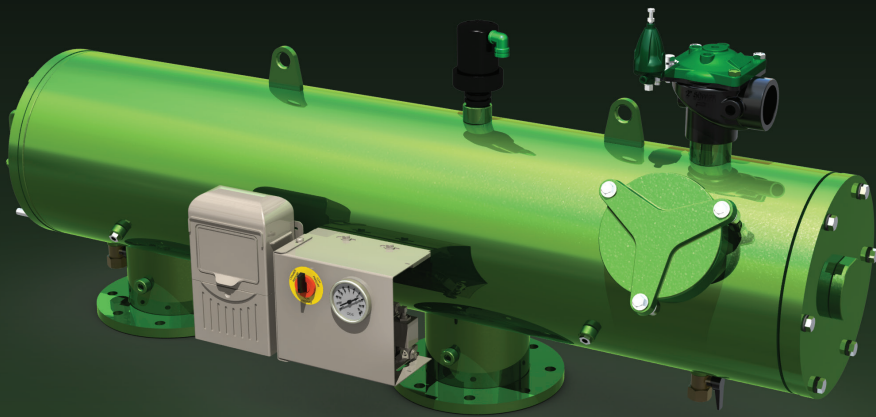

Operating Guidelines

Maximum working pressure: 8,0 bar

Maximum pressure: 10,0 bar

Ordering Information

Screen options: 100, 130, 200 micron

Body styles: angled, parallel, parallel long

F3200 Metal Screen Filters with Hydraulic Operation are the ideal choice for applications without AC electricity. The F3200 Filters utilizes continuous movement of the collector assembly to remove particles. The standard housing of the filter is made of carbon steel with a 120 micron protective coating of extra durable polyester, applied electrostatically and oven cured on a zinc-phosphate layer, and a sintered screen to provide maximum anti-corrosion protection both internally and externally.

The F3200 Metal Screen Filter with Hydraulic Operation is used as a primary filter for water containing large quantities of dirt; up to 50 ppm and from water sources such as rivers, lakes, wells, and recycled water. These filters are self-cleaning and continue to operate during the flushing cycle

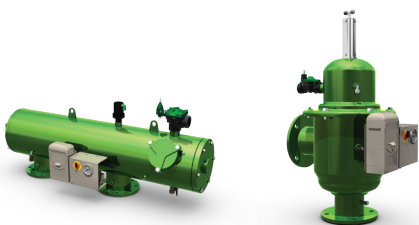

F3200 Metal Screen Filter with Hydraulic Operation (Automatic)

Product Summary

Inlet / Outlet	Inlet / Outlet	Body	Connections	Max. Flow Rate	Screen Area	Screens	Current Options
(inch)	(mm)			(m ³ /h)	(cm ²)	(Micron)	
2	50	Angled	BSP, BSTD, ISO16	25	850	100,130, 200	AC, DC
3	80	Angled, Parallel	BSTD, ISO16	40	1450, 2500	100,130, 200	AC, DC
4	100	Angled, Parallel	BSTD, ISO16	80	1450, 4000	100,130, 200	AC, DC
6	150	Angled, Parallel-L	BSTD, ISO16	150	4500, 6000	100,130, 200	AC, DC
8	200	Angled, Parallel, Parallel-L	BSTD, ISO16	300	6200, 6000, 8000	100,130, 200	AC, DC
10	250	Parallel	BSTD, ISO16	400	6000	100,130, 200	AC, DC
12	300	Parallel	BSTD, ISO16	470	8000	100,130, 200	AC, DC
14	350	Parallel	BSTD, ISO16	550	8000	100,130, 200	AC, DC
12 (Long)	300 (Long)	Parallel Long	BSTD, ISO16	600	10050	100,130, 200	AC, DC
14 (Long)	350 (Long)	Parallel Long	BSTD, ISO16	800	10050	100,130, 200	AC, DC
16 (Long)	400 (Long)	Parallel Long	BSTD, ISO16	1000	10050	100,130, 200	AC, DC
18 (Long)	450 (Long)	Parallel Long	BSTD, ISO16	1300	16150	100,130, 200	AC, DC
20 (Long)	500 (Long)	Parallel Long	BSTD, ISO16	1600	16150	100,130, 200	AC, DC

Product Dimensions and Weight - Parallel

Size	B	D	A	E	H	L	L1	Weight
(inch)	(mm)	(mm)	(mm)	(mm)	(mm)	(mm)	(mm)	(kg)
3	80	300	430	680	360	1280	2280	162
4	100	300	600	680	360	1470	2580	195
6	150	300	600	680	360	1470	2580	200
8	200	300	780	740	780	1720	3080	295
10	250	400	780	740	780	1720	3080	300
12	300	400	990	740	780	2030	3630	335
14	350	400	990	740	780	2030	3630	360
12 (Long)	300	450	1200	670	880	2340	4250	430
14 (Long)	350	450	1200	670	880	2340	4250	450
16 (Long)	400	450	1200	670	880	2340	4250	465
18 (Long)	450	600	1400	820	1160	2660	4750	635
20 (Long)	500	600	1400	820	1160	2660	4750	665

Product Dimensions and Weight - Angle

Size	B	D	A	E	H	T	Weight
(Inch)	(mm)	(mm)	(mm)	(mm)	(mm)	(mm)	(kg)
2 Thread	50	250	196	540	570	185	27
2 Flange	50	250	230	540	600	220	27
3 Thread	80	250	260	540	750	195	41
3 Flange	80	250	280	540	770	220	41
4	100	250	280	540	905	220	48
6	150	300	540	600	1310	320	65
8	200	300	700	600	1530	320	78

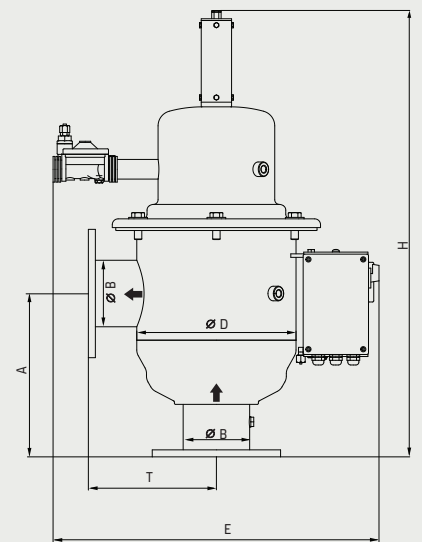
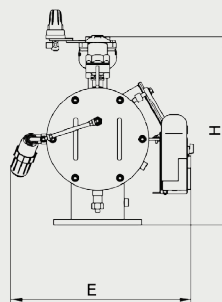
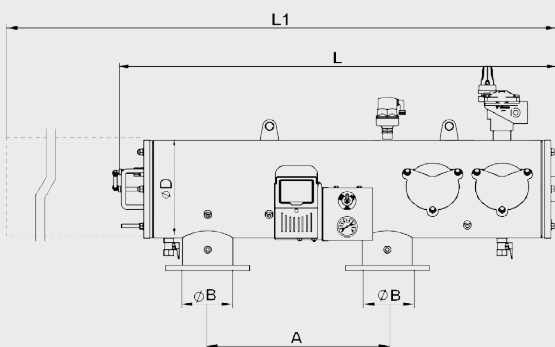

F3200 Metal Screen Filter with Hydraulic Operation (Automatic)

Product Head Loss Chart (bar) -80-150 mm Parallel

Size	Flow Rate (m ³ /h)												
	15	20	25	50	75	100	125	150	200	250	300	350	400
(inch)	Head Loss (Bar)												
3			0,05	0,21	0,46	0,83							
4				0,07	0,16	0,28	0,44	0,64	1,13				
6						0,06	0,09	0,12	0,22	0,35	0,5	0,68	0,89

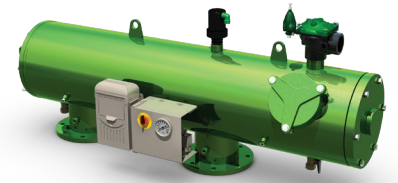

Product Head Loss Chart (bar) - 200-350 mm Parallel

Size	Flow Rate (m ³ /h)												
	200	300	400	500	600	700	800	900	1000	1200	1500	1800	2000
(inch)	Head Loss (Bar)												
8	0,08	0,17	0,3	0,47	0,68	0,92	1,2						
10		0,07	0,13	0,21	0,3	0,4	0,53	0,67	0,83	1,19			
12			0,07	0,11	0,15	0,21	0,27	0,34	0,42	0,61	0,95		
14				0,06	0,09	0,12	0,15	0,19	0,24	0,35	0,54	0,78	0,96

Head Loss/Flow Rate**

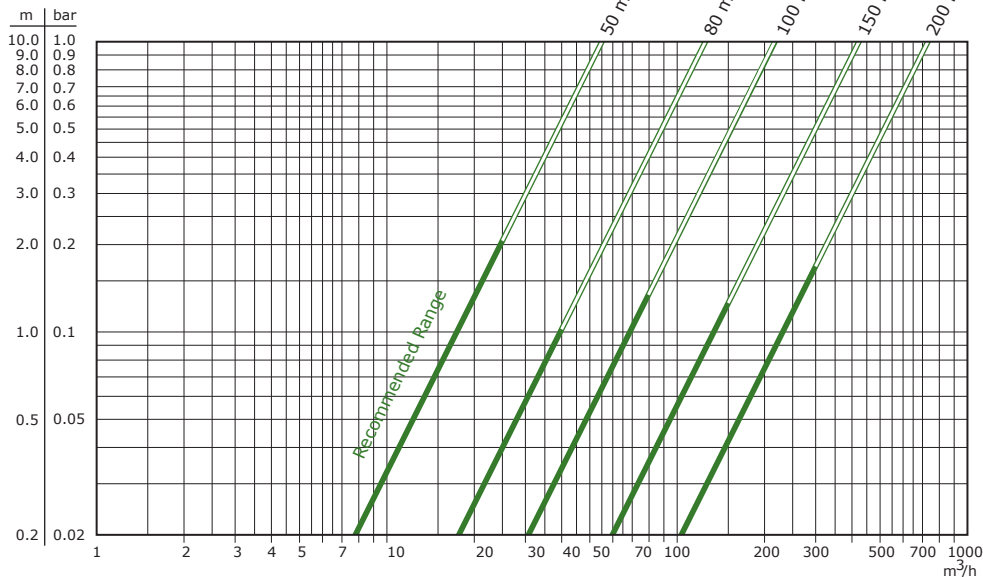

**For a clean filter and 130 micron screen

Product Head Loss Chart (bar) - 300-400 mm Parallel Long

Size	Flow Rate (m ³ /h)												
	400	500	600	700	800	900	1000	1200	1500	1800	2000	2300	2500
(inch)	Head Loss (Bar)												
12 L	0,07	0,11	0,15	0,21	0,27	0,34	0,42	0,61	0,95				
14 L		0,06	0,09	0,12	0,15	0,19	0,24	0,35	0,54	0,78	0,96		
16 L			0,05	0,07	0,09	0,12	0,15	0,21	0,33	0,48	0,59	0,78	0,92

F3200 Metal Screen Filter with Hydraulic Operation (Automatic)

Product Head Loss Chart (bar) - 450-500 Parallel Long

Size	Flow Rate (m ³ /h)												
	800	1000	1250	1500	1750	2000	2250	2500	2750	3000	3500	4000	4250
(inch)	Head Loss (Bar)												
18 L	0,06	0,09	0,14	0,20	0,28	0,36	0,46	0,56	0,68	0,81	1,10		
20 L		0,06	0,09	0,12	0,17	0,22	0,28	0,34	0,42	0,50	0,68	0,88	1,00

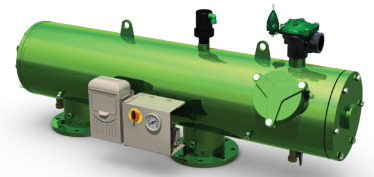

Head Loss/Flow Rate**

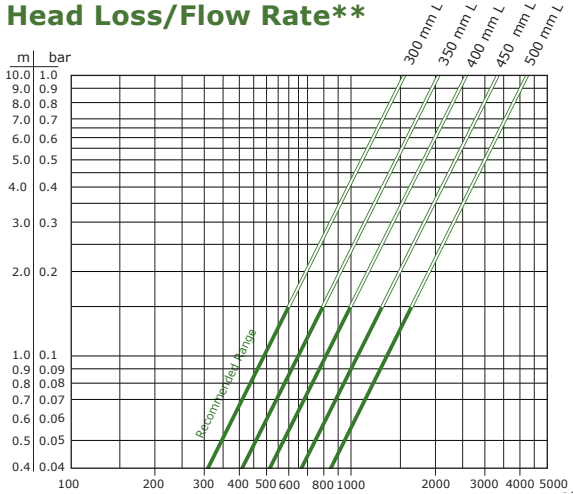

**For a clean filter and 130 micron screen m³/h

Product Head Loss Chart (bar) - 50-200 mm Angled

Size	Flow Rate (m ³ /h)											
	15	25	50	75	100	150	200	250	300	350	400	500
(inch)	Head Loss (Bar)											
2	0,07	0,21	0,83									
3			0,16	0,36	0,64							
4			0,05	0,11	0,19	0,43	0,76					
6					0,06	0,13	0,23	0,35	0,51	0,69	0,90	
8						0,04	0,08	0,12	0,17	0,23	0,30	0,47



Head Loss/Flow Rate**

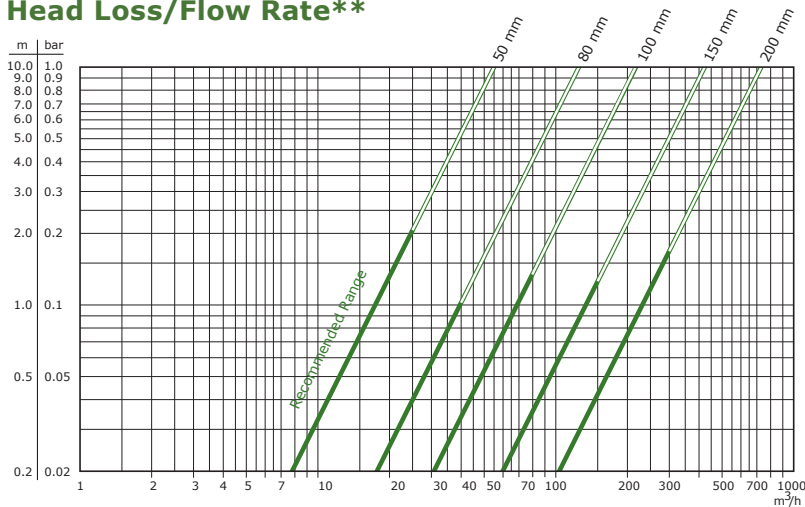

**For a clean filter and 130 micron screen m³/h