

OM-2 / 3

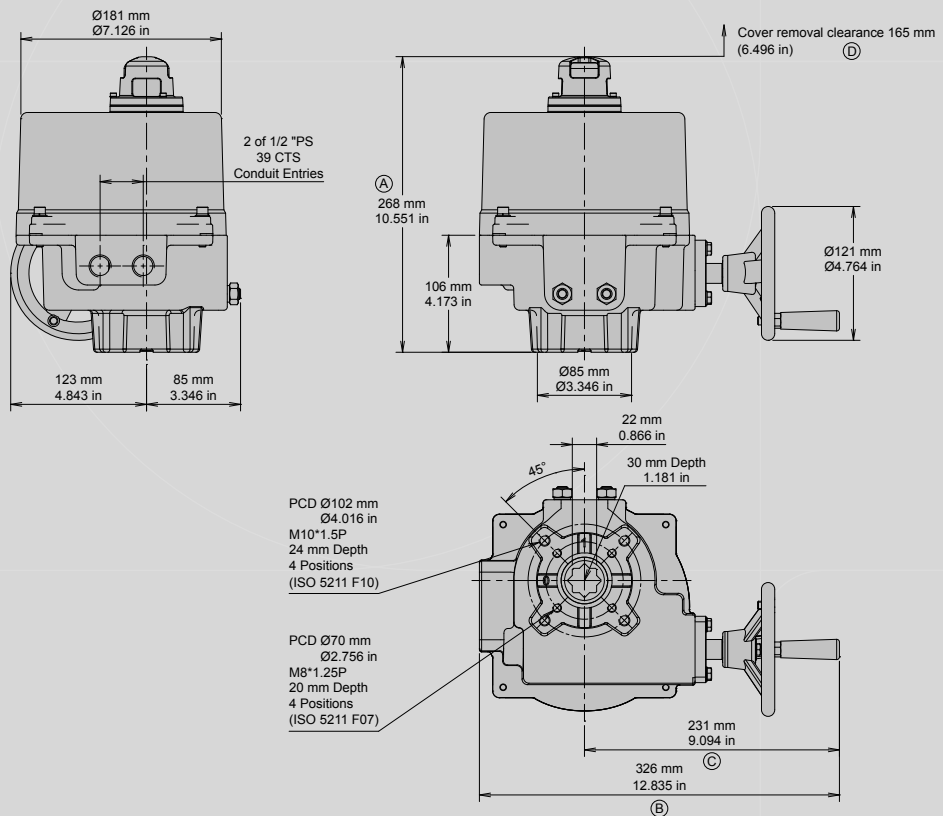

- Apply to DC models or 75% duty cycle, (A) 302 mm (11.890 in), Cover removal clearance, (D) 199 mm (7.834 in)
- With torque switch, (B) 363 mm (14.291 in), (C) 268 mm (10.551 in)

WIRING DIAGRAM – Quarter Turn Actuator

OM-2 ~ OM-8 110V , 220V AC 1-Phase

On-Off Controller , 75% duty cycle

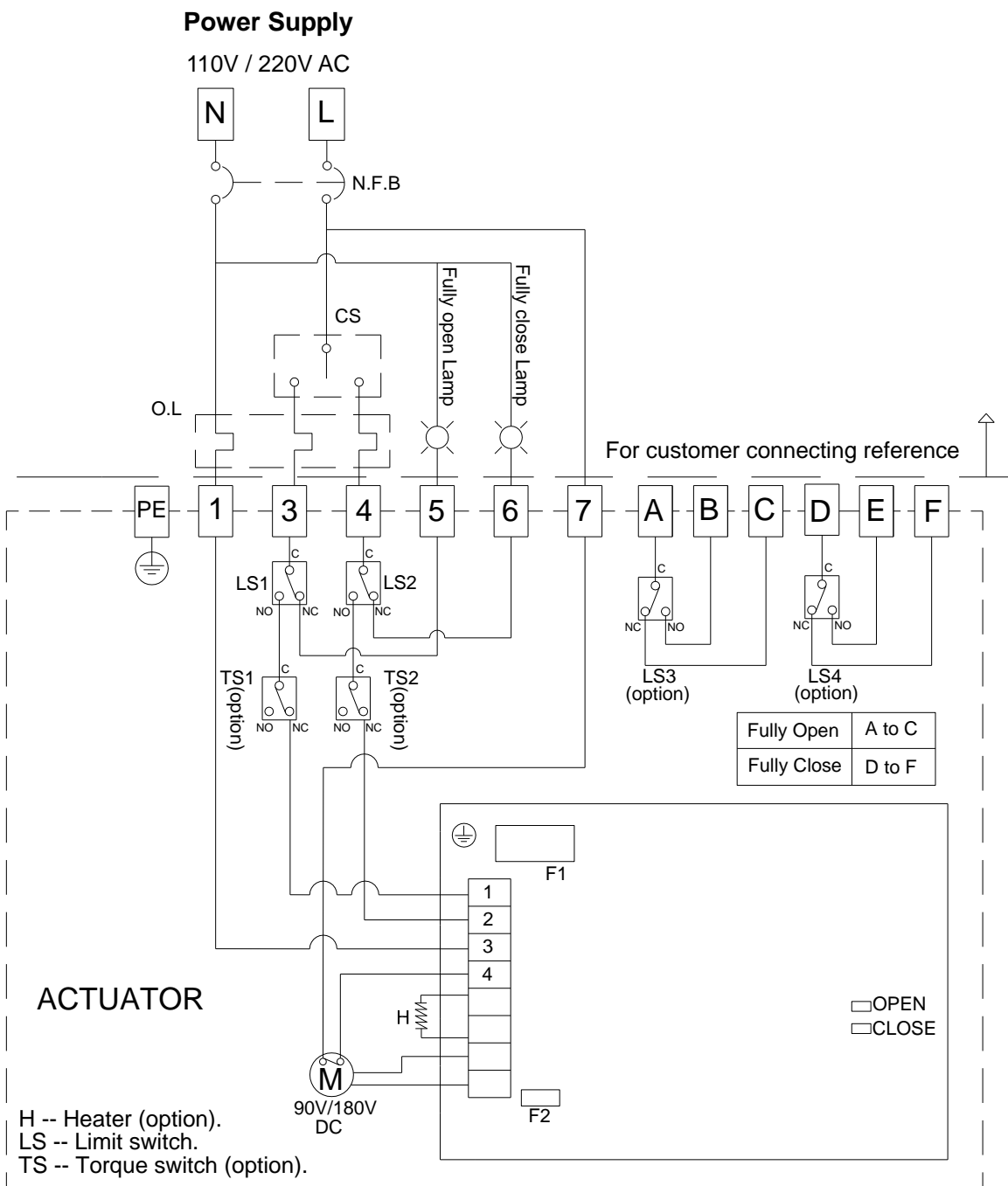

NOTE :

1. "N" connects to #1, "L" connects to #7.
2. "L" connects to #3 for "OPEN", "L" connects to #4 for "CLOSE".
3. Using less than 5A current for "A, B, C, D, E, F".